

HEAT PRESS CADDIE™

Installation Instructions

Available for heat press models:

- Sprint® Mag series 28x38 cm, 40x40 cm, 40x50 cm
- Sprint® Mag Hover 40x50 cm
- Maxx™ series 28x38 cm, 38x38 cm, 40x50 cm

See reverse for details.

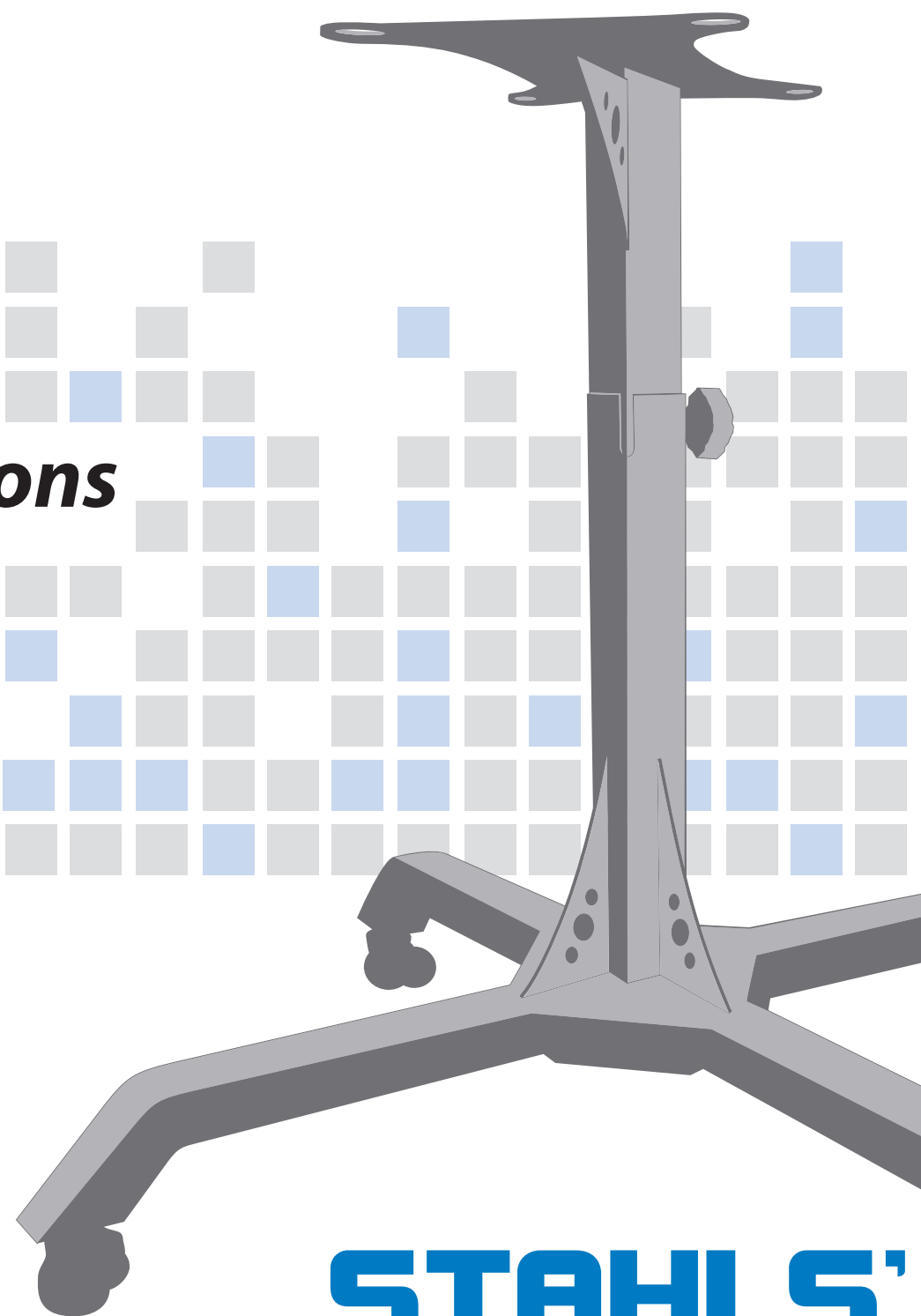

STAHL'S
a GroupeSTAHL company

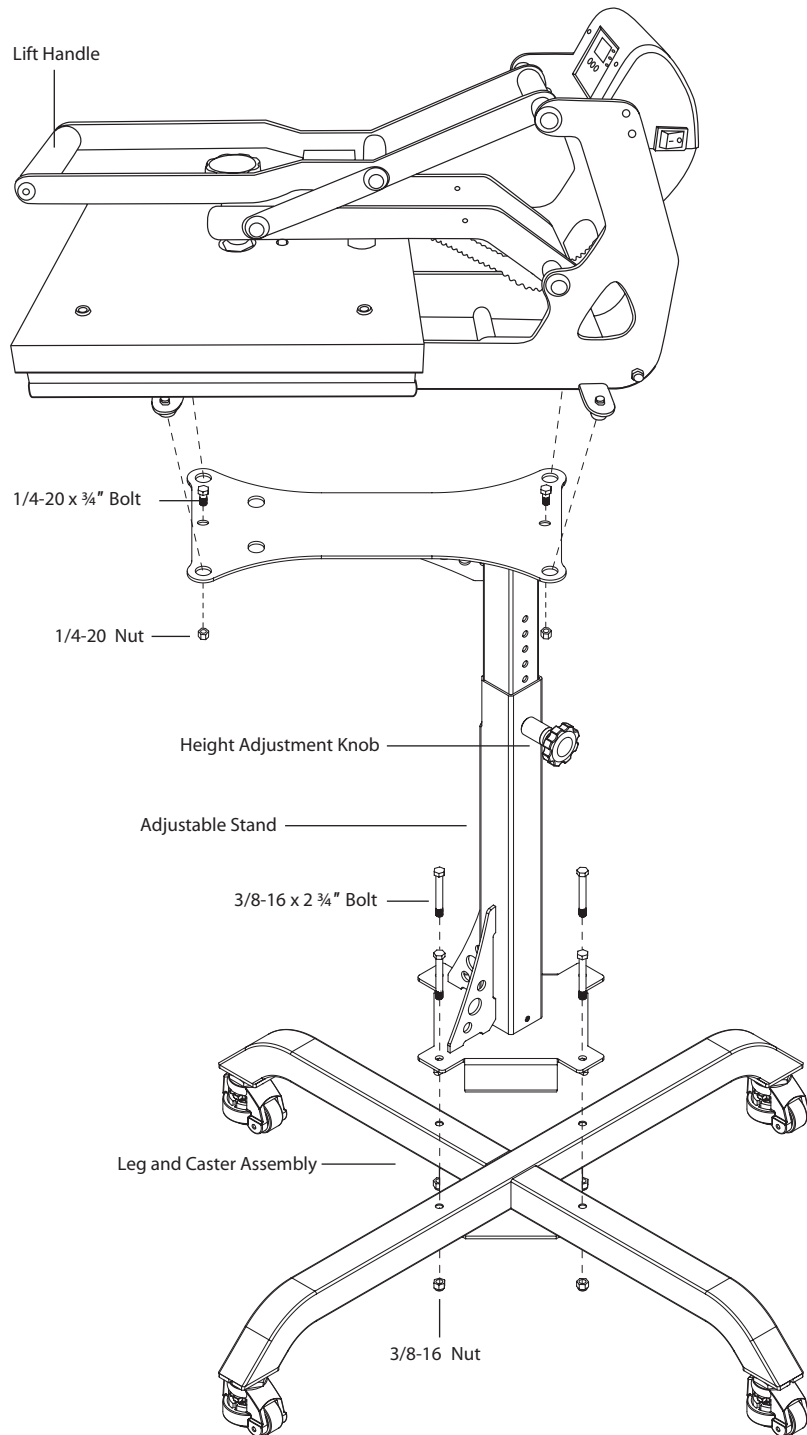

Installation Instructions

Tools Required: 9/16 and 7/16 socket wrench

- Step 1:** Using your 9/16 socket wrench, attach the leg and caster assembly to the adjustable stand with four 3/8-16 x 2 3/4" bolts and two nuts provided.
- Step 2:** With two people, lift heat press from the front, and back end of the press and place on stand. Align legs of your heat press with four holes located on top of the Heat Press Caddie™.
- Step 3:** Using your 7/16 socket wrench, connect the heat press with two 1/4-20 x 3/4" bolts and two nuts provided. Hold press securely until bolts have been tightened into place.
- Step 4:** Adjust the height of your heat press by pulling out on the height adjustment knob and rotate it in a counter clockwise motion. Lift up, or lower press until aligned with desired notch. Turn the knob clockwise to secure stand.
- Step 5:** Plug electrical cord back into press. You're ready to heat print.

For your safety, please read all instructions carefully.

- Two people are required to properly install the Heat Press Caddie. Use proper lifting techniques when placing your heat press on the stand.
- If press is in use, power off and allow to cool down completely before assembly.
- To avoid any potential tripping hazard, unplug the power cord from the heat press and from the outlet and set cord aside. (Never pull cord to disconnect, instead grasp from plug and pull to disconnect.)
- Before placing heat press on stand, press should be closed and in locked position. Using the lift handle, pull upper platen down completely and lock into position.
- Be sure casters are in the stationary position to keep stand from rolling during assembly. Rotate the stabilizing feet (located on the bottom of the leg and caster assembly) in a clockwise motion to lift the casters off of the floor.